

Алматы (7273)495-231
Ангарск (3955)60-70-56
Архангельск (8182)63-90-72
Астрахань (8512)99-46-04
Барнаул (3852)73-04-60
Белгород (4722)40-23-64
Благовещенск (4162)22-76-07
Брянск (4832)59-03-52
Владивосток (423)249-28-31
Владикавказ (8672)28-90-48
Владимир (4922) 49-43-18
Волгоград (844)278-03-48
Вологда (8172)26-41-59
Воронеж (473)204-51-73
Екатеринбург (343)384-55-89

Ижевск (3412)26-03-58
Иваново (4932)77-34-06
Иркутск (395)279-98-46
Казань (843)206-01-48
Калининград (4012)72-03-81
Калуга (4842)92-23-67
Кемерово (3842)65-04-62
Киров (8332)68-02-04
Коломна (4966)23-41-49
Кострома (4942)77-07-48
Краснодар (861)203-40-90
Красноярск (391)204-63-61
Курск (4712)77-13-04
Курган (3522)50-90-47
Липецк (4742)52-20-81

Магнитогорск (3519)55-03-13
Москва (495)268-04-70
Мурманск (8152)59-64-93
Набережные Челны (8552)20-53-41
Нижний Новгород (831)429-08-12
Новокузнецк (3843)20-46-81
Ноябрьск (3496)41-32-12
Новосибирск (383)227-86-73
Омск (3812)21-46-40
Орел (4862)44-53-42
Оренбург (3532)37-68-04
Пенза (8412)22-31-16
Петрозаводск (8142)55-98-37
Псков (8112)59-10-37
Пермь (342)205-81-47

Ростов-на-Дону (863)308-18-15
Рязань (4912)46-61-64
Самара (846)206-03-16
Саранск (8342)22-96-24
Санкт-Петербург (812)309-46-40
Саратов (845)249-38-78
Севастополь (8692)22-31-93
Симферополь (3652)67-13-56
Смоленск (4812)29-41-54
Сочи (862)225-72-31
Ставрополь (8652)20-65-13
Сыктывкар (8212)25-95-17
Сургут (3462)77-98-35
Тамбов (4752)50-40-97
Тверь (4822)63-31-35

Тольяти (8482)63-91-07
Томск (3822)98-41-53
Тула (4872)33-79-87
Тюмень (3452)66-21-18
Улан-Удэ (3012)59-97-51
Ульяновск (8422)24-23-59
Уфа (347)229-48-12
Хабаровск (4212)92-98-04
Чебоксары (8352)28-53-07
Челябинск (351)202-03-61
Череповец (8202)49-02-64
Чита (3022)38-34-83
Якутск (4112)23-90-97
Ярославль (4852)69-52-93

Киргизия (996)312-96-26-47

Россия (495)268-04-70

Казахстан (772)734-952-31

<https://cleaver.nt-rt.ru> || cea@nt-rt.ru

Комплектные системы с блоками питания multiSUB

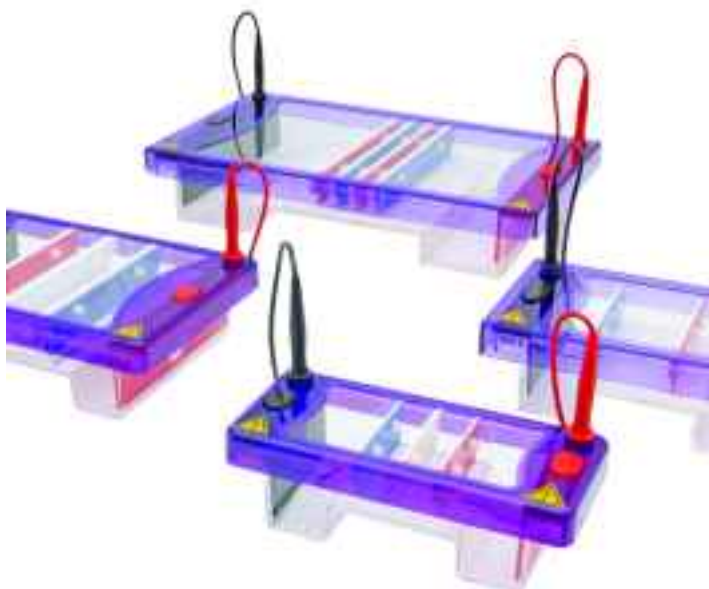

multiSUB Horizontal System

multiSUB[®] Horizontal Electrophoresis Units

Instruction Manual

Catalogue Numbers

MSMINI7

MSMINI10

MSMINIDUO

MSCHOICE7

MSCHOICE10

MSCHOICE15

MSCHOICETRIO

MSCHOICEST20

MSCHOICEST25

MSMIDI7

MSMIDI10

MSMIDIDUO

MSMAXI10

MSMAXI15

MSMAXI20

MSMAXIDUO

MSMAXI25

Safety Information



When used correctly, these units pose no health risk. However, these units can deliver dangerous levels of electricity and are to be operated only by qualified personnel following the guidelines laid out in this instruction manual. Anyone intending to use this equipment should read the complete manual thoroughly. The unit must never be used without the safety lid correctly in position. The unit should not be used if there is any sign of damage to the external tank or lid.

These units comply with the following European directives:

***2006/95/CE Low Voltage Directive and 2014/30/UE (official Title 2004/108/EC)
EMC Electromagnetic Compatibility***

By virtue of the following harmonised standards:

BS EN IEC 61010-1: 2010 Safety Testing of Lab Equipment

BS EN IEC 61326-1:2013 EMC Electro Magnetic Compatibility

Packing List

Each multiSUB unit includes a tank, wired electrodes, lid and the following items:

SKU	Tray	Tray Dams	Combs	Loading Guides	Cables
MSMINI7	MS7-UV7, 7 x 7cm (W x L)	MS7-UVDAM, Pack of 2	2 x MS7-8-1, 1mm, 8 sample	MS7-LG – Strips, MS7-WP – Platform	CSL-CAB
MSMINI10	MS7-UV10, 7 x 10cm (W x L)	MS7-UVDAM, Pack of 2	2 x MS7-8-1, 1mm, 8 sample	MS7-LG – Strips, MS7-WP – Platform	CSL-CAB
MSMINIDUO	MS7-UV7, MS7-UV10	MS7-UVDAM, Pack of 2	2 x MS7-8-1, 1mm, 8 sample	MS7-LG – Strips, MS7-WP – Platform	CSL-CAB
MSMIDI7	MS10-UV7, 10 x 7cm (W x L)	MS10-UVDAM, Pack of 2	2 x MS10-16-1, 1mm, 16 sample	MS10-LG – Strips, MS10-WP – Platform	CSL-CAB
MSMIDI10	MS10-UV10, 10 x 10cm (W x L)	MS10-UVDAM, Pack of 2	2 x MS10-16-1, 1mm, 16 sample	MS10-LG – Strips, MS10-WP – Platform	CSL-CAB
MSMIDIDUO	MS10-UV7, MS10-UV10	MS10-UVDAM, Pack of 2	2 x MS10-16-1, 1mm, 16 sample	MS10-LG – Strips, MS10-WP – Platform	CSL-CAB
MSCHOICE7	MS15-UV7, 15 x 7cm (W x L)	MS15-UVDAM, Pack of 2	2 x MS15-20-1, 1mm, 20 sample	MS15-LG – Strips, MS15-WP – Platform	CSL-CAB
MSCHOICE10	MS15-UV10, 15 x 10cm (W x L)	MS15-UVDAM, Pack of 2	2 x MS15-20-1, 1mm, 20 sample	MS15-LG – Strips, MS15-WP – Platform	CSL-CAB
MSCHOICE15	MS15-UV15, 15 x 15cm (W x L)	MS15-UVDAM, Pack of 2	2 x MS15-20-1, 1mm, 20 sample	MS15-LG – Strips, MS15-WP – Platform	CSL-CAB
MSCHOICETRIO	MS15-UV7, MS15-UV10, MS15-UV15	MS15-UVDAM, Pack of 2	2 x MS15-20-1, 1mm, 20 sample	MS15-LG – Strips, MS15-WP – Platform	CSL-CAB
MSCHOICEST20	MS15-UVST20, 15 x 20 cm, (W x L)	MS15-UVDAM, Pack of 2	4 x MS15-28MC-1, 1mm thick, 28 sample MC	MS15-LG – Strips, MS15-WP – Platform	CSL-CAB
MSCHOICEST25	MS15-UVST25, 15 x 25 cm, (W x L)	MS15-UVDAM, Pack of 2	4 x MS15-28MC-1, 1mm thick, 28 sample MC	MS15-LG – Strips, MS15-WP – Platform	CSL-CAB

MSMAXI10	MS20-UV10, 20 x 10cm (W x L)	MS20-UVDAM, Pack of 2	2 x MS20-20-1, 1mm, 20 sample	MS20-LG – Strips, MS20-WP – Platform	CSL- CAB
MSMAXI15	MS20-UV15, 20 x 15cm (W x L)	MS20-UVDAM, Pack of 2	2 x MS20-20-1, 1mm, 20 sample	MS20-LG – Strips, MS20-WP – Platform	CSL- CAB
MSMAXI20	MS20-UV20, 20 x 20cm (W x L)	MS20-UVDAM, Pack of 2	2 x MS20-20-1, 1mm, 20 sample	MS20-LG – Strips, MS20-WP – Platform	CSL- CAB
MSMAXIDUO	MS20-UV10, MS20-UV20	MS20-UVDAM, Pack of 2	2 x MS20-20-1, 1mm, 20 sample	MS20-LG – Strips, MS20-WP – Platform	CSL- CAB
MSMAXI25	MS20-UV25, 20 x 25cm (W x L)	MS20-UVDAM, Pack of 2	2 x MS20-20-1, 1mm, 20 sample	MS20-LG – Strips, MS20-WP – Platform	CSL- CAB

Packing List Checked by: _____

Date: _____

The packing lists should be referred to as soon as the units are received to ensure that all components have been included. The unit should be checked for damage when received.

Cleaver Scientific is liable for all missing or damaged parts / accessories within 7 days after customers have received this instrument package. Please contact Cleaver Scientific immediately regarding this issue. If no response within such period is received from the customer, Cleaver Scientific will no longer be liable for replacement/damaged parts.

Please contact your supplier if there are any problems or missing items.

Specifications

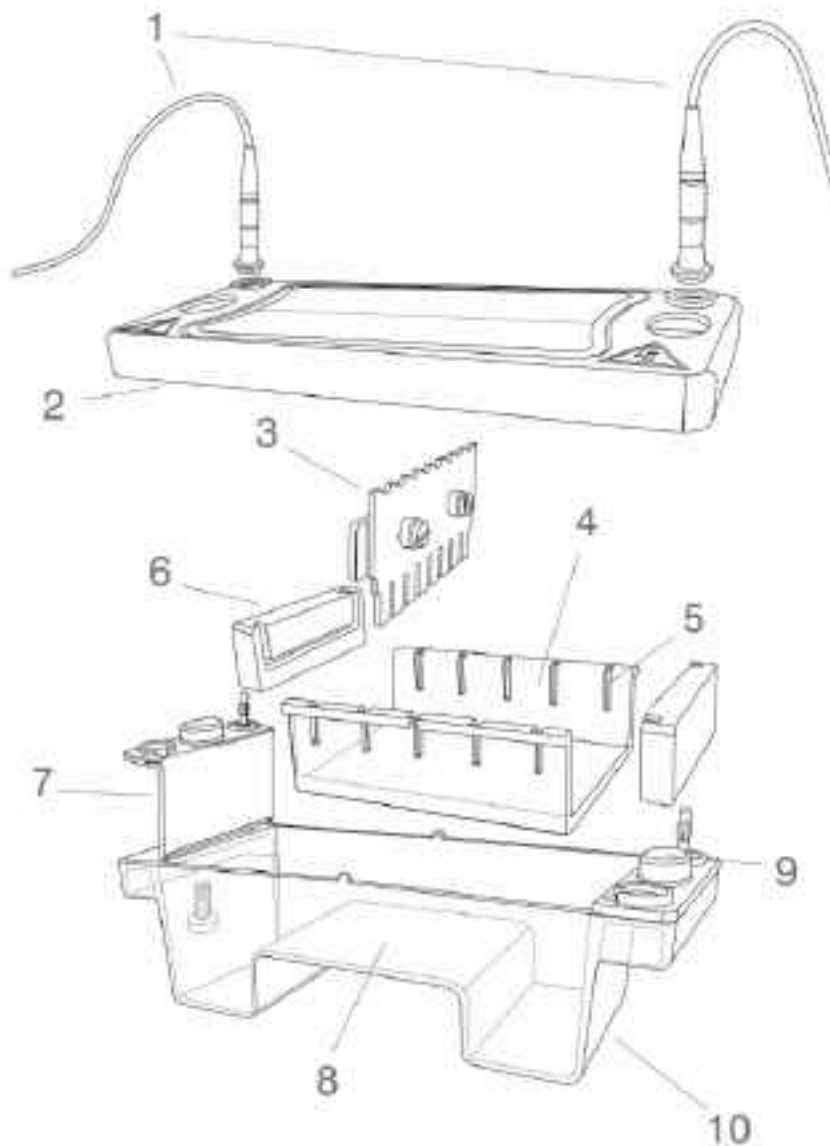

1	Power supply cables	1500V rated with retractable 4mm connectors
2	Safety lid and viewing pane	High impact moulded acrylic construction
3	Height adjustable combs	Acrylic
4	UV transparent gel tray	UV transparent above 300nm, Moulded acrylic
5	Comb Slots	Allow multiple combs per tray
6	Casting dams	Natural rubber
7	Colour-coded electrodes	Moulded acrylic, 99.99% platinum wire, gold plated 4mm plugs
8	Gel platform	Notched to fix gel position
9	Safety lid thumb locators	For safe removal of lid
10	Moulded buffer tank	High Impact moulded acrylic construction for chemical compatibility and shock resistance

- Maximum altitude 2,000m.
- Temperature range between 4°C and 65°C.
- Maximum relative humidity 80% for temperatures up to 31°C decreasing linearly to 50% relative humidity at 40°C.
- Not for outdoor Use.

This apparatus is rated POLLUTION DEGREE 2 in accordance with IEC 664.

POLLUTION DEGREE 2, states that: "Normally only non-conductive pollution occurs.

Occasionally, however, a temporary conductivity caused by condensation must be expected".

Setting up the Horizontal Gel Tanks

Fitting Electrodes

- Note the position of the lid on the unit. This shows the correct polarity and the correct orientation of the cables, black is negative and red positive.
- Remove the lid from the unit. Note if the lid is not removed, fitting the cables may result in un-tightening of the gold plug and damage to the electrode.
- Screw the cables into the tapped holes as fully as possible so that there is no gap between the lid and the leading edge of the cable fitting.
- Refit the lid.

Fitting Loading Guides

These can be fitted to enhance visibility of the wells if desired. They can be fitted to the white vinyl platform sheet or to the unit itself.

1. Seat the tray in the unit and note the position of the comb grooves. The samples run black to red but the trays can be used frontward or backwards so ensure that the comb grooves closest to the black electrode are marked.

2. Remove the tray.
3. Peel the back off the loading guide and carefully apply the loading guide directly to the gel platform.

The unit is now ready to be used.

Gel Preparation

The Table below shows the volume of agarose solution required to make the desired agarose gel for each unit tray size. For a standard 0.7% agarose gel, add 0.7 grams of agarose to 100 ml of 1x TAE or TBE solution. The same 1X solution should be used in the tank buffer solution.

multiSUB® Mini	Tray	7 x 7 cm	7 x 10 cm	
	Gel volume for a 5mm thick gel	25 mL	35 mL	
multiSUB® Midi	Tray	10 x 7 cm	10 x 10 cm	
	Gel volume for a 5mm thick gel	35 mL	50 mL	
multiSUB® Choice	Tray	15 x 7 cm	15 x 10 cm	15 x 15 cm
	Gel volume for a 5mm thick gel	52.5 mL	75 mL	112.5 mL
multiSUB® Choice STRETCH	Tray	15 x 20 cm	15 x 25 cm	
	Gel volume for a 5mm thick gel	150 mL	187.5 mL	
multiSUB® Maxi	Tray	20 x 10 cm	20 x 15 cm	20 x 20 cm
	Gel volume for a 5mm thick gel	100 mL	150 mL	200 mL

1. Add the agarose powder to a conical flask.
2. Add the appropriate amount of 1x TAE or TBE solution from the table above. To prevent evaporation during the dissolving steps below, the conical flask should be covered with parafilm.
3. Dissolve the agarose powder by heating the agarose either on a magnetic hot plate with stirring bar or in a microwave oven. If using the microwave method, the microwave should be set at around a 400 watt or medium setting and the flask swirled every minute. The solution

should be heated until all crystals are dissolved. This is best viewed against a light background. Crystals appear as translucent crystals. These will interfere with sample migration if not completely dissolved.

The gel must be cooled to between 50°C and 60°C degrees before pouring.

Gel Pouring

The multiSUB® range of units allows three different methods of gel casting:

1. Casting Dams
2. Flexicaster
3. Traditional Tape

Casting Dams

1. To fit the casting dams, place one casting dam on the bench with the groove facing upwards (1). Push the edge of the tray down firmly into the groove (2). Repeat this for the other side (3). The dams should be fitted so that there is no gap between the sides of the tray and the groove in the dams. This will ensure that there is no possibility of gel leakage.
2. Place the comb(s) in the grooves. Each tray has more than one comb groove so that multiple combs can be used. Using multiple combs increases sample number available per gel but decreases run length and care must be taken to ensure that samples from the first wells do not migrate into the lanes of the second comb wells.
3. Pour in the agarose carefully so as not to generate bubbles. Any bubbles that do occur can be smoothed to the edge of the gel and dispersed using a pipette tip.
4. Allow the agarose to set, ensuring that the gel remains undisturbed.

Flexicaster

1. Level the Flexicaster base by adjusting the feet so that the bubble is exactly central.
2. Insert the desired length tray into the Flexicaster such that one end of the tray is pushed up and seals against the silicone mat of the permanent end of the Flexicaster.
3. Position the movable end of the Flexicaster so that the silicone mat is pushed against the other end of the tray.
4. Turn the cam so that the silicone mat tightly seals against the side of the tray. Pour in the agarose carefully so as not to generate bubbles. Any bubbles that do occur can be smoothed to the edge of the gel and dispersed using a pipette tip.
5. Allow the agarose to set, ensuring that the gel remains undisturbed.
6. Carefully remove the gel casting gates and comb and transfer the gel including tray to the main tank.

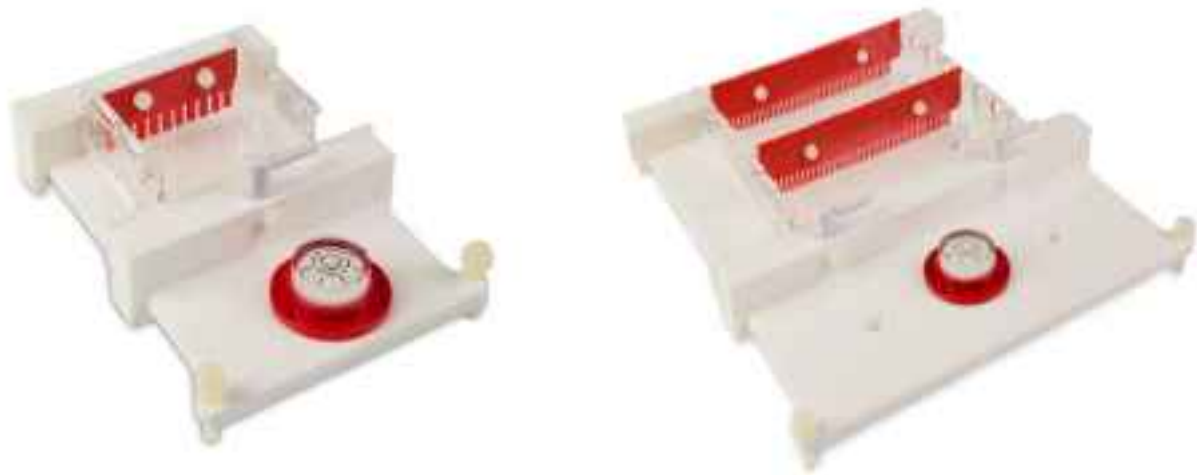

MS7-FC and MS20-FC Flexicasters

Tape

1. Autoclave or plastic backed general tape should be used. A length 5cm longer than the width of each end of the tray should be cut. One length should be placed over one end of the tray and stuck 1cm in from the tray edge. This should then be folded, and the edges sealed securely. Repeat for the other end and place onto a level surface for gel pouring.
2. Place the comb(s) in the grooves. Each tray has more than one comb groove so that multiple combs can be used. Using multiple combs increases sample number available per gel but decreases run length and care must be taken to ensure that samples from the first wells do not migrate into the lanes of the second comb wells.
3. Pour in the agarose carefully so as not to generate bubbles. Any bubbles that do occur can be smoothed to the edge of the gel and dispersed using a pipette tip.
4. Allow the agarose to set, ensuring that the gel remains undisturbed.
5. Carefully remove the gel casting gates and comb and transfer the gel including tray to the main tank.

Running the Gel

1. Mix the sample to be loaded with sample buffer – see solutions for common sample buffers. Usually 3ul of sample buffer is adequate but less may be used with sample volumes of less than 10ul.
2. Fill the unit with buffer until the gel is just flooded with buffer. This will give the fastest resolution times. For enhanced quality of resolution of sample, fill the unit to 5mm above the gel.
3. Load the samples into the wells using pipettes. Multi-channel pipettes can be used for loading samples with MC compatible combs, see listing in accessories for identification of these.
4. Carefully place the lid on the tank and connect to a power supply.
5. Typically, gels are run at between 90 and 150 volts. However, maximum voltages are indicated on the serial badge of each unit. It should be noted that higher voltages generally give faster but poorer quality sample resolution.

Gel Staining and Viewing

The Multi Sub trays allow staining to be performed without removing the gel from the tray if this is preferred.

1. Transfer the gel to a vessel containing the appropriate volume of 0.5 µg/ml ethidium bromide stain for 15–30 minutes, see solutions for stock stain concentration and adjust to the volume used accordingly. The entire gel should be covered.

NOTE: Ethidium bromide is a suspected carcinogen and the necessary safety precautions should be taken.

2. De-stain the gel for 10–30 minutes in distilled water again ensuring the gel is completely immersed.
3. Rinse the gel twice for a couple of seconds with distilled water.
4. Transfer the gel to a UV Transilluminator.

The samples will often appear as brighter, clearer bands when photographed or viewed using a gel documentation system. However, if the gel bands are too faint then the staining procedure should be adjusted so that there is less de-staining. If there is too much background, then the staining procedure should be adjusted so that there is more de-staining.

Solutions

0.5M EDTA stock (500mL) dissolve in 400 ml distilled water:

- 93.05g EDTA disodium salt

Fill to 500 ml litre final volume with distilled water

50X TAE stock (1L) dissolve in 750 ml distilled water:

- 242 g tris base (FW = 121)
- 57.1 ml glacial acetic acid
- 100 ml 0.5 M EDTA (pH 8.0).

Fill to 1 litre final volume with distilled water

10X TBE stock (1L) dissolve in 750 ml distilled water:

- 108 g tris base (FW = 121)
- 55 g boric acid (FW = 61.8)
- 40 ml 0.5 M EDTA (pH 8.0)

Fill to 1 litre final volume with distilled water

Loading Dye

10x sample buffer stock consists of 50% glycerol, 0.25% bromophenol blue, and 0.25% xylene cyanole FF in 1x TAE buffer. Only 1–10 ml of the 10x loading dye should be prepared.

Ethidium Bromide Solution

Add 10 mg of Ethidium Bromide to 1 ml distilled water.

References

1. Sambrook, Fritsch, and Maniatis, **Molecular Cloning A Laboratory Manual**, Second Edition, Cold Spring Harbor Laboratory Press, 1989.
2. **Current Protocols in Molecular Biology**, Greene Publishing Associates and Wiley-Interscience, 1989.

Troubleshooting

Problem	Cause	Solution
Bands sharp but not enough bands seen	Gel agarose percentage too high Incomplete digestion	Decrease agarose percentage. Review enzyme activity, digest further.
Band smearing and streaking	Agarose has improper endosmosis Salt concentration in sample too high Excessive power and heating Sample spilled out of well Incomplete digestion, nuclease contamination, bad enzyme Sample wells cast through the gel. Sample leaks along bottom of running surface	Reduce salt concentration to $\leq 0.1M$. Reduce voltage. See electrophoresis instructions. Apply sample carefully. Increase gel thickness for large sample volumes. Adjust comb height. Heat sample. Review enzyme activity. Digest sample further. Comb should be placed to 1 to 2 mm above the base of the running surface.
Curved line or distortion of bands	Bubbles in sample wells	Remove bubbles prior to electrophoresis.
Curved bands, smiles	Sample overload	Reduce load.
Differential relative mobilities	Sample spilled out of wells Unit not levelled	Samples should have proper density. Apply carefully. Level unit. Use a steady work bench.
Gels crack	Too high voltage gradient, especially with low melting temperature agarose or low gel strength gels	Reduce voltage. Run gel at lower temperature.
High MW bands sharp; low MW bands smeared	Gel agarose percentage too low	Increase agarose percentage. Switch to polyacrylamide.
Ragged bands	Sample density incorrect Sample well deformed Excessive power or heating	See sample application instructions. Carefully remove comb, especially from soft gels. Make sure gel has solidified. Cooling soft gels aids in comb removal. Reduce voltage. See electrophoresis instructions.
Slanted lanes (bands)	Gel not fully solidified Comb warped or at an angle	Gel to solidify for at least 30-45min. Check alignment of comb.

Care and Maintenance

Cleaning Horizontal Units

Units are best cleaned using warm water and a mild detergent. **Water at temperatures above 60°C can cause damage to the unit and components.**

The tank should be thoroughly rinsed with warm water or distilled water to prevent build-up of salts, but care should be taken not to damage the enclosed electrode and vigorous cleaning is not necessary or advised.

Air drying is preferably before use.

The units should only be cleaned with the following:

Warm water with a mild concentration of soap or other mild detergent.

Compatible detergents include dishwashing liquid, Hexane and Aliphatic hydrocarbons

The units should not be left in detergents for more than 30 minutes.

The units should never come into contact with the following cleaning agents, these will cause irreversible and accumulative damage:

Acetone, Phenol, Chloroform, Carbon tetrachloride, Methanol, Ethanol, Isopropyl alcohol, Alkalis.

RNase Decontamination

This can be performed using the following protocol:

Clean the units with a mild detergent as described above.

Wash with 3% hydrogen peroxide (H₂O₂) for 10 minutes.

Rinsed with 0.1% DEPC-(diethyl pyro carbonate) treated distilled water,

Caution: DEPC is a suspected carcinogen. Always take the necessary precautions when using.

RNaseZAP™ (Ambion) can also be used. Please consult the instructions for use with acrylic gel tanks.

Ordering information

Catalogue No.	Product description
MSMINI7	multiSUB® Mini, 7 x 7cm UV Tray, 2 x 8 sample combs, loading guides and dams
MSMINI10	multiSUB® Mini, 7 x 10cm UV Tray, 2 x 8 sample combs, loading guides and dams
MSMINIDUO	multiSUB® Mini, 7 x 7cm & 7 x 10cm UV Tray, 2 x 8 sample combs, loading guides and dams
MS7-UV7	7 x 7cm UV Tray
MS7-UV10	7 x 10cm UV Tray
MS7-PE	Positive Electrode
MS7-NE	Negative Electrode
MS7-UVDAM	Casting Dams
MS7/10-FC	multiSUB® Mini/Midi Flexi caster
MS7-LG	Adhesive Loading Guides
MS7-WP	Viewing Platform
MSMINICP	Cool-pack and Platform
MSMINIBSB	Buffer Saver Blocks, pk/2 saves 100ml of buffer
MS7-UVS	7cm UV Gel Scoop
CSL-CAB	Electrophoresis cable (Black & Red)
MSMIDI7	multiSUB® Midi, 10 x 7cm UV Tray, 2 x 16 sample combs, loading guides and dams
MSMIDI10	multiSUB® Midi, 10 x 10cm UV Tray, 2 x 16 sample combs, loading guides and dams
MSMIDIDUO	multiSUB® Midi, 10 x 7cm & 10 x 10cm UV Tray, 2 x 16 sample combs, loading guides and dams
MS10-UV7	10 x 7cm UV Tray
MS10-UV10	10 x 10cm UV Tray
MS10-PE	Positive Electrode
MS10-NE	Negative Electrode
MS10-UVDAM	Casting Dams
MS7/10-FC	multiSUB® Mini/Midi Flexi caster
MS10-LG	Adhesive Loading Guides
MS10-WP	Viewing Platform
MSMIDICP	Cool-pack and Platform
MSMIDIBSB	Buffer Saver Blocks, pk/2 saves 100ml of buffer

MS10-UVS	10cm UV Gel Scoop
CSL-CAB	Electrophoresis cable (Black & Red)
MSCHOICE7	multiSUB®™ Choice 15 x 7cm UV Tray, 2 x 20 sample combs, loading guides and dams
MSCHOICE10	multiSUB®™ Choice 15 x 10cm UV Tray, 2 x 20 sample combs, loading guides and dams
MSCHOICE15	multiSUB®™ Choice 15 x 15cm UV Tray, 2 x 20 sample combs, loading guides and dams
MSCHOICETRIO	multiSUB®™ Choice Trio 15 x 7,10 & 15cm UV Tray, 2 x 20 sample combs, loading guides and dams
MSCHOICETRIO15	multiSUB®™ Choice Trio 15 3 x 15cm UV tray, 2x 20 sample combs, loading guides and dams
MSCHOICEST20	multiSUB®™ Choice Stretch 20 15 x 20cm UV tray, 4 x 28 sample combs, loading guides and dams
MSCHOICEST25	multiSUB®™ Choice Stretch 25 15 x 25cm UV tray, 4 x 28 sample combs, loading guides and dams
MS15-UV7	15 x 7cm UV Tray
MS15-UV10	15 x 10cm UV Tray
MS15-UV15	15 x 15cm UV Tray
MS15-UVST20	15 x 20cm UV Tray
MS15-UVS	15cm UV Gel Scoop
MS15-UVDAM	Casting Dams
MS15-PE	Positive Electrode
MS15-NE	Negative Electrode
MSMS15-LG	Adhesive Loading Guides
MS15-WP	Viewing Platform
MSCHOICECP	Cool-Pack and Platform
MS15/20-FC	multiSUB® Choice/ Maxi Flexi caster
MSMAXI10	20 x 10cm UV Tray, 2 x 20 sample, 1mm thick combs, casting dams, loading guides
MSMAXI15	20 x 15cm UV Tray, 2 x 20 sample, 1mm thick combs, casting dams, loading guides
MSMAXI20	20 x 20cm UV Tray, 2 x 20 sample, 1mm thick combs, casting dams, loading guides
MSMAXIDUO	20 x 10 & 20 x 20cm UV Tray, 2 x 20 sample, 1mm thick combs, casting dams, loading guides
MSMAXI25	20 x 25cm UV Tray, 2 x 20 sample, 1mm thick combs, casting dams, loading guides
MS20-UV10	20 x 10cm UV Tray

MS20-UV15	20 x 15cm UV Tray
MS20-UV20	20 x 20cm UV Tray
MS20-UV25	20 x 25cm UV Tray
MS20-UVDAM	Casting Dams
MS15/20-FC	multiSUB Choice/Maxi Flexi caster
MS20-LG	Adhesive Loading Guides
MS20-WP	Viewing Platform
MS20-PE	Positive Electrode
MS20-NE	Negative Electrode
MS20-UVS	20cm UV Gel Scoop
MSMAXICP	Cool-Pack and Platform
MSMAXIBSB	Buffer Saver Blocks pk/2 saves 450ml of buffer

Comb options

Catalogue No.	Tank	Thickness	Sample Number	Tooth Width (mm)	Volume (ul)
MS7-1-0.75	Mini	0.75	1	45	152
MS7-2-0.75	Mini	0.75	2	20	68
MS7-4-0.75	Mini	0.75	4	10.63	36
MS7-8MC-0.75	Mini	0.75	8	2.5	8
MS7-8-0.75	Mini	0.75	8	5.5	19
MS7-10-0.75	Mini	0.75	10	4	14
MS7-12-0.75	Mini	0.75	12	3	10
MS7-16-0.75	Mini	0.75	16	2.2	7
MS7-1-1	Mini	1	1	45	203
MS7-2-1	Mini	1	2	20	90
MS7-4-1	Mini	1	4	10.63	48
MS7-8MC-1	Mini	1	8	2.5	11
MS7-8-1	Mini	1	8	5.5	25
MS7-10-1	Mini	1	10	4	18
MS7-12-1	Mini	1	12	3	14
MS7-16-1	Mini	1	16	2.2	10
MS7-1-1.5	Mini	1.5	1	45	304
MS7-2-1.5	Mini	1.5	2	20	135

MS7-4-1.5	Mini	1.5	4	10.63	72
MS7-8MC-1.5	Mini	1.5	8	2.5	17
MS7-8-1.5	Mini	1.5	8	5.5	37
MS7-10-1.5	Mini	1.5	10	4	27
MS7-12-1.5	Mini	1.5	12	3	20
MS7-16-1.5	Mini	1.5	16	2.2	15
MS7-1-2	Mini	2	1	45	405
MS7-2-2	Mini	2	2	20	180
MS7-4-2	Mini	2	4	10.63	96
MS7-8MC-2	Mini	2	8	2.5	23
MS7-8-2	Mini	2	8	5.5	50
MS7-10-2	Mini	2	10	4	36
MS7-12-2	Mini	2	12	3	27
MS7-16-2	Mini	2	16	2.2	20
MS10-1-0.75	Midi	0.75	1	80	270
MS10-2-0.75	Midi	0.75	2	35	118
MS10-4-0.75	Midi	0.75	4	17	57
MS10-8-0.75	Midi	0.75	8	9	30
MS10MC-10-0.75	Midi	0.75	10	6	20
MS10-12-0.75	Midi	0.75	12	5	17
MS10-16-0.75	Midi	0.75	16	3.5	12
MS10-20MC-0.75	Midi	0.75	20	3	10
MS10-1-1	Midi	1	1	80	360
MS10-2-1	Midi	1	2	35	158
MS10-4-1	Midi	1	4	17	77
MS10-8-1	Midi	1	8	9	41
MS10MC-10-1	Midi	1	10	6	27
MS10-12-1	Midi	1	12	5	23
MS10-16-1	Midi	1	16	3.5	16
MS10-20MC-1	Midi	1	20	3	14
MS10-1-1.5	Midi	1.5	1	80	540
MS10-2-1.5	Midi	1.5	2	35	236
MS10-4-1.5	Midi	1.5	4	17	115
MS10-8-1.5	Midi	1.5	8	9	61

MS10MC-10-1.5	Midi	1.5	10	6	41
MS10-12-1.5	Midi	1.5	12	5	34
MS10-16-1.5	Midi	1.5	16	3.5	24
MS10-20MC-1.5	Midi	1.5	20	3	20
MS10-1-2	Midi	2	1	80	720
MS10-2-2	Midi	2	2	35	315
MS10-4-2	Midi	2	4	17	153
MS10-8-2	Midi	2	8	9	81
MS10MC-10-2	Midi	2	10	6	54
MS10-12-2	Midi	2	12	5	45
MS10-16-2	Midi	2	16	3.5	32
MS10-20MC-2	Midi	2	20	3	27
MS15-1-0.75	Choice	0.75	1	110	371
MS15-2-0.75	Choice	0.75	2	50	169
MS15-4-0.75	Choice	0.75	4	27	91
MS15-10-0.75	Choice	0.75	10	10	34
MS15-10MC-0.75	Choice	0.75	10	6.5	22
MS15-12-0.75	Choice	0.75	12	9	30
MS15-14MC-0.75	Choice	0.75	14	6.5	22
MS15-16-0.75	Choice	0.75	16	6	20
MS15-20-0.75	Choice	0.75	20	4.75	16
MS15-28MC-0.75	Choice	0.75	28	2.5	8
MS15-35-0.75	Choice	0.75	35	2.2	7
MS15-1-1	Choice	1	1	110	495
MS15-2-1	Choice	1	2	50	225
MS15-4-1	Choice	1	4	27	122
MS15-10-1	Choice	1	10	10	45
MS15-10MC-1	Choice	1	10	6.5	29
MS15-12-1	Choice	1	12	9	41
MS15-14MC-1	Choice	1	14	6.5	29
MS15-16-1	Choice	1	16	6	27
MS15-20-1	Choice	1	20	4.75	21
MS15-28MC-1	Choice	1	28	2.5	11
MS15-35-1	Choice	1	35	2.2	10

MS15-1-1.5	Choice	1.5	1	110	743
MS15-2-1.5	Choice	1.5	2	50	338
MS15-4-1.5	Choice	1.5	4	27	182
MS15-10-1.5	Choice	1.5	10	10	68
MS15-10MC-1.5	Choice	1.5	10	6.5	44
MS15-12-1.5	Choice	1.5	12	9	61
MS15-14MC-1.5	Choice	1.5	14	6.5	44
MS15-16-1.5	Choice	1.5	16	6	41
MS15-20-1.5	Choice	1.5	20	4.75	32
MS15-28MC-1.5	Choice	1.5	28	2.5	17
MS15-35-1.5	Choice	1.5	35	2.2	15
MS15-1-2	Choice	2	1	110	990
MS15-2-2	Choice	2	2	50	450
MS15-4-2	Choice	2	4	27	243
MS15-10-2	Choice	2	10	10	90
MS15-10MC-2	Choice	2	10	6.5	59
MS15-12-2	Choice	2	12	9	81
MS15-14MC-2	Choice	2	14	6.5	59
MS15-16-2	Choice	2	16	6	54
MS15-20-2	Choice	2	20	4.75	43
MS15-28MC-2	Choice	2	28	2.5	23
MS15-35-2	Choice	2	35	2.2	20
MS20-1-0.75	Maxi	0.75	1	150	506
MS20-2-0.75	Maxi	0.75	2	70	236
MS20-4-0.75	Maxi	0.75	4	34	115
MS20-10-0.75	Maxi	0.75	10	16	54
MS20-16-0.75	Maxi	0.75	16	9	30
MS20-20MC-0.75	Maxi	0.75	20	6	20
MS20-25-0.75	Maxi	0.75	25	4.7	16
MS20-30-0.75	Maxi	0.75	30	3.8	13
MS20-36-0.75	Maxi	0.75	36	3.2	11
MS20-40MC-0.75	Maxi	0.75	40	2.5	8
MS20-1-1	Maxi	1	1	150	675
MS20-2-1	Maxi	1	2	70	315

MS20-4-1	Maxi	1	4	34	153
MS20-10-1	Maxi	1	10	16	72
MS20-16-1	Maxi	1	16	9	41
MS20-20MC-1	Maxi	1	20	6	27
MS20-25-1	Maxi	1	25	4.7	21
MS20-30-1	Maxi	1	30	3.8	17
MS20-36-1	Maxi	1	36	3.2	14
MS20-40MC-1	Maxi	1	40	2.5	11
MS20-1-1,5	Maxi	1.5	1	150	1013
MS20-2-1.5	Maxi	1.5	2	70	473
MS20-4-1.5	Maxi	1.5	4	34	230
MS20-10-1.5	Maxi	1.5	10	16	108
MS20-16-1.5	Maxi	1.5	16	9	61
MS20-20MC-1.5	Maxi	1.5	20	6	41
MS20-25-1.5	Maxi	1.5	25	4.7	32
MS20-30-1.5	Maxi	1.5	30	3.8	26
MS20-36-1.5	Maxi	1.5	36	3.2	22
MS20-40MC-1.5	Maxi	1.5	40	2.5	17
MS20-1-2	Maxi	2	1	150	1350
MS20-2-2	Maxi	2	2	70	630
MS20-4-2	Maxi	2	4	34	306
MS20-10-2	Maxi	2	10	16	144
MS20-16-2	Maxi	2	16	9	81
MS20-20MC-2	Maxi	2	20	6	54
MS20-25-2	Maxi	2	25	4.7	42
MS20-30-2	Maxi	2	30	3.8	34
MS20-36-2	Maxi	2	36	3.2	29
MS20-40MC-2	Maxi	2	40	2.5	23

Related Products

Catalogue No.	Product description
nanoPAC-300	Mini Power supply, 300V, 400mA, 60W -100 -240VAC
nanoPAC-500	Mini Power supply, 500V, 400mA, 120W -100 -240VAC
POWERPRO300	MIDI Power Supply, 300V, 700mA, 150 – 100 -240VAC
omniDOCPROSAFE	OMNIDOC plus Blue LED Epi-illumination Module (OMNIDOC-BL), and 520, 560 & 580nm filters (OMNIDOC-SYBR, -AF560 & -AF580); and White Light Table (OMNIDOC-WLT). Requires a PC or laptop
CSL-AG5	Agarose Powder 5g, Low EEO
CSL-AG100	Agarose Powder 100g, Low EEO
CSL-AG500	Agarose Powder 500g, Low EEO
CSL-AG1000	Agarose Powder 1000g, Low EEO (2x500g bottles)
CSL-AG2000	Agarose Powder 2000g, Low EEO (4x500g bottles)
CSL-AG5000	Agarose Powder 5000g, Low EEO (10x500g bottles)
CSL-AG10KG	Agarose Powder 10Kg, Low EEO (20x500g bottles)
CSL-LMA5	Agarose Powder 5g, Low Melting Point
CSL-LMA50	Agarose Powder 50g, Low Melting Point
CSL-LMA100	Agarose Powder 100g, Low Melting Point
CSL-HRA100	Agarose Powder 100g, High Resolution
CSL-HRA500	Agarose Powder 500g, High Resolution
CSL-AGTAB	Agarose Tablet 100g, Low EEO (200 x 0.5g tablets, supplies as 20 blister packs of 10 x 0.5g tablets)
CSL-RUNSAFE	CSL-RUNSAFE - Package: 1 ml/vial
CSL-TBEP	Powdered Tris-Borate-EDTA Running Buffer- 10 sachets (1litre/pk)
TBE10X1L	Cleaver Buffer Tris-Borate-EDTA Running Buffer- 10 x 1L
TBE10X5	Cleaver Buffer Tris-Borate-EDTA Running Buffer- 10 x 5L
TAE50X1L	Cleaver Buffer Tris-Borate-EDTA Running Buffer- 50 x 1L
TAE50X5L	Cleaver Buffer Tris-Borate-EDTA Running Buffer- 50 x 5L
CSL-MDNA-100BH	100bp DNA ladder, 100 – 300bp, 1 x 500µl vial
CSL-MDNA-100BP	100bp DNA ladder, 100 – 1500bp, 1 x 500µl vial
CSL-MDNA-1KB	1Kb DNA ladder, 250 – 10Kb, 1 x 500µl vial
CSL-MDNA-50BP	50bp DNA ladder, 50 – 1500bp, 1 x 500µl vial
CSL-MDNA-BR	Broad Range DNA ladder, 100bp – 10Kb, 1 x 500µl vial
CSL-MDNA-HR	High Range DNA ladder, 250bp – 25Kb, 1 x 500µl vial
CSL-LOADDYE	10x Bromophenol Blue Loading Dye, 1mL
CSL-LOADDYE10	10x Bromophenol Blue Loading Dye, 10mL
SAFEVIEW	BLUE Light Transilluminator 21 x 21 cm
CSLUVTS312	UV Transilluminator, small 21 x 21 cm, 312nm
CSL-GELX4	4mm x 1mm, Gel Cutting Tips, 250/ bag
CSL-GELX4RACK	4mm x 1mm, Gel Cutting Tips, 5 racks of 48
CSL-GELX6.5	6.5mm x 1mm, Gel Cutting Tips, 250/ bag
CSL-GELX6.5RACK	6.5mm x 1mm, Gel Cutting Tips, 5 racks of 48
CSLQSPIN	Mini Centrifuge complete with 1.5/2.0 ml rotor, strip tube rotor, 0.5 and 0.4 ml adapters, 230V, Purple lid
CV20	Cleaver Pipette - Volume; 2 - 20µl

Warranty

The Cleaver Scientific Ltd. (CSL) multiSUB® Horizontal Electrophoresis units have a warranty against manufacturing and material faults of twelve months from date of customer receipt.

If any defects occur during this warranty period, CSL will repair or replace the defective parts free of charge.

This warranty does not cover defects occurring by accident or misuse or defects caused by improper operation.

Units where repair or modification has been performed by anyone other than CSL or an appointed distributor or representative are no longer under warranty from the time the unit was modified.

Units which have accessories or repaired parts not supplied by CSL or its associated distributors have invalidated warranty.

CSL cannot repair or replace free of charge units where improper solutions or chemicals have been used. For a list of these please see the Care and Maintenance subsection.

Алматы (7273)495-231
Ангарск (3955)60-70-56
Архангельск (8182)63-90-72
Астрахань (8512)99-46-04
Барнаул (3852)73-04-60
Белгород (4722)40-23-64
Благовещенск (4162)22-76-07
Брянск (4832)59-03-52
Владивосток (423)249-28-31
Владикавказ (8672)28-90-48
Владимир (4922) 49-43-18
Волгоград (844)278-03-48
Вологда (8172)26-41-59
Воронеж (473)204-51-73
Екатеринбург (343)384-55-89

Ижевск (3412)26-03-58
Иваново (4932)77-34-06
Иркутск (395)279-98-46
Казань (843)206-01-48
Калининград (4012)72-03-81
Калуга (4842)92-23-67
Кемерово (3842)65-04-62
Киров (8332)68-02-04
Коломна (4966)23-41-49
Кострома (4942)77-07-48
Краснодар (861)203-40-90
Красноярск (391)204-63-61
Курск (4712)77-13-04
Курган (3522)50-90-47
Липецк (4742)52-20-81

Киргизия (996)312-96-26-47

Магнитогорск (3519)55-03-13
Москва (495)268-04-70
Мурманск (8152)59-64-93
Набережные Челны (8552)20-53-41
Нижний Новгород (831)429-08-12
Новокузнецк (3843)20-46-81
Ноябрьск (3496)41-32-12
Новосибирск (383)227-86-73
Омск (3812)21-46-40
Орел (4862)44-53-42
Оренбург (3532)37-68-04
Пенза (8412)22-31-16
Петрозаводск (8142)55-98-37
Псков (8112)59-10-37
Пермь (342)205-81-47

Россия (495)268-04-70

Ростов-на-Дону (863)308-18-15
Рязань (4912)46-61-64
Самара (846)206-03-16
Саранск (8342)22-96-24
Санкт-Петербург (812)309-46-40
Саратов (845)249-38-78
Севастополь (8692)22-31-93
Симферополь (3652)67-13-56
Смоленск (4812)29-41-54
Сочи (862)225-72-31
Ставрополь (8652)20-65-13
Сыктывкар (8212)25-95-17
Сургут (3462)77-98-35
Тамбов (4752)50-40-97
Тверь (4822)63-31-35

Казахстан (772)734-952-31

Тольяти (8482)63-91-07
Томск (3822)98-41-53
Тула (4872)33-79-87
Саранск (8342)22-96-24
Улан-Удэ (3012)59-97-51
Ульяновск (8422)24-23-59
Уфа (347)229-48-12
Хабаровск (4212)92-98-04
Чебоксары (8352)28-53-07
Челябинск (351)202-03-61
Череповец (8202)49-02-64
Чита (3022)38-34-83
Якутск (4112)23-90-97
Ярославль (4852)69-52-93